

Bruno Vertical Platform Lift™

Residential

*Strong and
Durable...*

*Convenient
Access to your
Porch or Deck*



Superior Styling



Residential Vertical Platform Lift from Bruno

Now your porch or deck is totally accessible through this affordable solution from the leaders in residential accessibility technology.

Peace of Mind is not bought...it is given...through the skill, dedication, and vision of proud craftsmen who design and build products to increase the independence of people around the world.

Safety is the watchword.

Reliability is the standard.

Value is the promise.

Vertical Platform Lift Safety Features



The entire bottom of the platform is spring sensitive, shutting the unit down if an obstruction is encountered.



Automatic self-lowering folding ramp provides convenient entrance for mobility devices when in the "down" position, and a safety barrier in the "up" position.



Simple, accessible push button or optional paddle controls with emergency stop switch are easy to operate.



Optional – Top landing gate includes mechanical interlock released only with platform at the top landing.

Quality Craftsmanship

The Bruno name has always meant trust.

Our Vertical Platform Lift (VPL) extends that promise to another category of solutions “for your independence”.

For the consumer who insists upon performance and reliability, the Bruno VPL-3100 offers the perfect solution for your home accessibility needs.

Performance

With a rated weight capacity of 750 lb (340 kg), Bruno’s Vertical Platform Lift can handle virtually any power wheelchair or scooter and occupant. Its rugged dependability and powerful performance provide complete confidence.

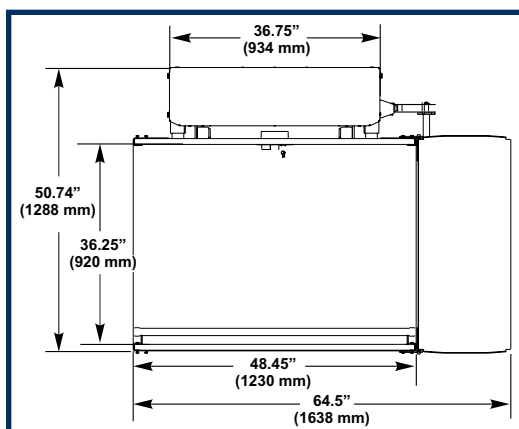

Dimensions shown are for the standard platform size.

**optional platform sizes and configurations available.*

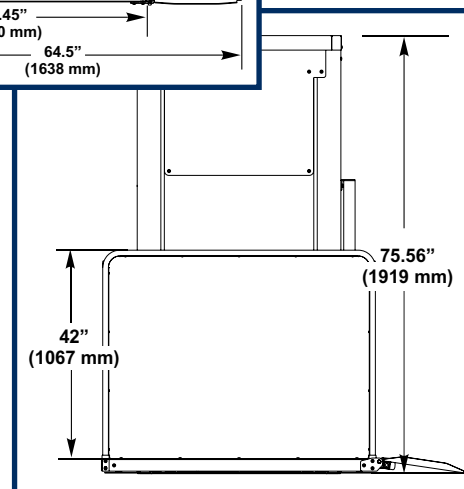

Dimensions shown are for the model VPL-3153

For detailed specifications and dimensions go to www.bruno.com.

VPL Options



Optional keyed call/send controls offer additional security and ease of operation.



Stay dry with an optional Canopy! It can be retrofitted for previously installed units. (Not available for 90° platforms)



Battery Powered Option

Bruno offers added peace of mind with our new battery powered Vertical Platform Lift.

Your life doesn't stop when the power goes out – now your VPL doesn't have to stop either!

Our battery powered VPL provides access in and out of your home even during a power outage.

VPL-3100 Series

Vertical Platform Lift™

Vertical Platform Lift™ Series Specifications

Standard Features

- Automatic self-lowering folding ramp
- Weather protected controls
- 750 lb/340 kg lifting capacity
- 53 in/1364 mm maximum floor to floor height (Model VPL-3153)
- 75 in/1905 mm maximum floor to floor height (Model VPL-3175)
- Separate up and down push-button switches with key switch control
- Emergency stop switch on platform – push to stop, pull to reset
- Welded steel tubular guide construction with formed 16 GA sheet steel guarding
- Totally enclosed formed-steel bottom safety pan
- Acme screw drive, with backup safety nut

- Weather resistant powder coated paint throughout
- Bruno's Gold Warranty – Two years for major components and one year on parts

Optional Equipment

- Top landing gate includes call/send controls with key and mechanical interlock (released only when platform is at top landing)
- Platform Gate
- Manual lowering hand tool
- Landing call/send station with key switch
- 90° Platform (adjacent exit at top landing)
- Paddle Controls
- Platform Canopy
- Cold weather package

Standard AC Powered Unit

Model VPL-3100 Series

- 1 hp motor, 1750 rpm, 110-120 Volt 15 Amp 60 Hz dedicated power
- Solenoid actuated screw braking at the landings
- CSA/C-US listed

DC Battery Powered Unit

Model VPL-3100B Series

- 1/2 hp motor, 1750 rpm 24 Vdc
- 5A 24 Vdc output battery charger, 120 Vac 60 Hz 5A max input power required
- Standard 17 Amp hour batteries included
- Optional 34 Amp hour batteries
- CSA/C-US listed



Ask us about our other...

Home accessibility solutions and automotive products



ELECTRA-RIDE™ ELITE
Model SRE-2010



ELECTRA-RIDE™ III
Model CRE-2110



VEHICLE LIFTS



TURNING AUTOMOTIVE SEATING™ (TAS™)

Represented by:



BRUNO INDEPENDENT LIVING AIDS, INC.®
1780 Executive Drive, P.O. Box 84, Oconomowoc, WI 53066
www.bruno.com

